

SSR SERIES MODULES AND BACKPLANES

This guide describes the mechanical and electrical aspects of the solid state relay (SSR) Series modules and backplanes. It also describes how to install and configure them for use with National Instruments data acquisition (DAQ) devices. The SSR Series consists of the following digital signal conditioning modules and backplanes:

- Output modules
 - OAC5
 - OAC5A
 - ODC5
- Input modules
 - IAC5
 - IAC5A
 - IDC5
- Backplanes
 - 8-module
 - 16-module
 - 24-module
 - 32-module

Introduction

You can use the SSR Series digital signal conditioning modules with your PC and National Instruments DAQ devices to control or sense voltages from field devices. The SSR modules are high-performance, fully encapsulated devices that interface the PC to field devices via optical isolation. These modules plug into one of the SSR backplanes, which are available with 8-, 16-, 24-, and 32-module capacities. Each backplane has screw terminals for field connections. A 50-pin connector connects the backplane to the DAQ device. The backplanes also have light emitting diodes (LEDs) that indicate the status of each SSR module.

What You Need to Get Started

To set up and use the SSR Series modules and backplanes you need the following:

- SSR Series module backplane kit and documentation
- SSR Series module
- National Instruments DAQ device
- Cable and/or SC-205X device
- Number 1 and number 2 Phillips-head screwdrivers
- ¼ in. flat-head screwdriver

Module Operation

SSR modules optically isolate the field signals from the computer, preventing any possibility of damage to the computer by overvoltage transients on these lines. The optical isolation is rated for surges up to 4,000 V.



Note

All SSR modules use negative logic.

Input Modules

Input SSR modules sense voltages from a field source and return a logic value to the National Instruments DAQ device. If a voltage within the selected input range for the input module is present, it returns a logic low signal to the DAQ device, otherwise it returns a logic high signal.

Output Modules

Output SSR modules sense a logic value from the DAQ device to control external devices. They control power in a manner similar to conventional relays. If the DAQ device sends a logic low signal, the output module turns on and current flows. If the DAQ device sends a logic high signal, the output module turns off.

Output SSR modules are similar to conventional relays, but there are some important differences. Unlike conventional relays, these solid state relays require voltage on the load side. Current needs to flow through them in the on state, or they turn off even if a logic low signal is at their input. This occurrence is referred to as dropout. If a solid state relay drops out, you must turn it off with a logic high signal before you can turn it on again.

The dropout voltage and current specifications for the output modules are given in the *Manufacturer Data Sheets* section. For most control applications, such as controlling motors or lamps, these requirements are not difficult to meet.

A second difference between these output modules and conventional relays is that they do not turn off completely. A small leakage current flows all the time even in the off state. For most control applications, this current causes no problems.

Output SSR modules require a certain amount of current from the digital control for the module to turn on. If the DAQ device sends a logic high signal, the output module turns off and no current flows. If the DAQ device sends a logic low signal, the output module turns on and current flows from the +DC control or V_{cc} to the -DC control. This current must be large enough to turn on the output module. If the DAQ device or digital control cannot sink enough current through the -DC control, the module does not turn on. Refer to Table 1 to find the minimum logic control current required to turn on each output module.

Table 1. Minimum Control Logic Current Required

Output Module	Control Current
ODC5	5 mA
OAC5	12 mA
OAC5A	12 mA



Note

Make sure you pair the output module with a DAQ device that provides sufficient control current. For example, the following National Instruments DAQ devices do not work reliably with the SSR-OAC-5 and SSR-OAC-5A: the DIO-24 (6503), DIO-96 (6508), Lab/1200 Series, AT-MIO-16D/AT-MIO-16DE extended DIO lines, DAQCard-700, PC-LPM-16, and PC-AO-2DC.

SSR Backplanes

This section describes the SSR backplane in detail including connection, function, SSR module installation, and field connections.

Connection

All four SSR backplanes function similarly, but they accommodate a different number of modules. Each backplane has a special cabling scheme to maximize the number of modules in use.

The SSR backplanes are divided into ports of eight modules each. The 8-, 16-, 24-, and 32-module backplanes have one, two, three, and four ports respectively.

Table 2 shows backplanes that need an interface to convert the digital input/output (DIO) lines to map correctly. Table 2 also shows cables that are available for connecting DAQ devices and SSR backplanes. Refer to the National Instruments catalogue if your system is not listed in the table.

Table 2. SSR Backplane Cabling Guide

DAQ Device	8-Module Backplane	16-Module Backplane	24-Module Backplane	32-Module Backplane
DIO-24 (6503) except DAQCard-DIO-24	NB1 cable or SC-205X adapter ² (via NB8 cable)	NB1 cable	NB1 cable	NA
DAQCard-DIO-24	PSH27-50F-D1 ¹ cable or SC-205X adapter (via NB8 cable)	PSH27-50F-D1 ¹ cable	PSH27-50F-D1 ¹ cable	NA
DIO-32HS (6533)	SC-205X adapter ² (via NB8 cable)	NA	NA	R6850-D1 cable ¹
DIO-96 (6508)	SC-205X adapter ² (via NB8 cable)	SC-205X adapter (via NB8 cable)	SC-205X adapter (via NB8 cable)	NA
50-pin MIO Series, 68-pin MIO E (60xx) Series, Lab/1200 Series, DAQCard-700, PC-LPM-16, PC-AO-2DC	SC-205X adapter ² (via NB8 cable)	NA	NA	NA
100-pin MIO E (60xx) Series	R1005050 cable ¹ or SC-205X adapter ² (via NB8 cable)	R1005050 cable ¹	R1005050 cable ¹	NA
¹ These cables are available separately and are not included with the SSR Series backplane. ² This adapter is available separately. See the National Instruments Catalogue for information about cabling to connect an SC-205X to your DAQ device. NA means not applicable				

If you need an interface, use the SC-205X Series devices. You can connect backplanes that do not need an SC-205X Series device directly to a DAQ device because the modules map directly to one or more DIO ports.

The SC-205X Series devices break out different DIO ports for use with different products. For information on connecting, mounting, and cabling your DIO ports using the SC-205X, see your *SC-205X Series User Manual*.

**Caution**

Do not attempt to connect the SSR backplane to a host computer DAQ device for which it was not designed. Such connections can damage any or all SSR modules, the host computer, and the DAQ device. National Instruments is not liable for any damages resulting from incorrect connections.

The 32-module backplane connects the PCLK1 (OUT1) and PCLK2 (OUT2) signals of the DIO-32HS (6533) device to ground. When using a 32-module backplane, do not configure a device for any mode that uses the PCLK1 or PCLK2 line. Specifically, do not configure the DIO-32HS (6533) for burst handshaking mode, which uses PCLK, or write any data to port 4, which is the port that includes the PCLK1 and PCLK2 lines. Incorrect configuration can damage the host computer and your DAQ device. National Instruments is not liable for any damages resulting from incorrect configuration.

Configuring the Power Supply

This section describes how to configure the SSR backplane jumpers to get +5 VDC power to the SSR modules.

You can power the SSR module backplanes by either the DAQ device or an external power supply. You need external power when connecting to a DAQ device that does not supply external power or when the power needed for the SSR modules and any other accessories exceeds the power supplied by the DAQ device. Different DAQ devices supply different amounts of power; for example many supply 1 A. See the specifications of your device for more information.

The current needed for the SSR modules and accessories is the sum of the maximum logic supply current of all SSR modules connected to the DAQ device plus any other current needed by accessories connected to the same DAQ device.

To configure the SSR module backplane for external power or DAQ device power you need to set a jumper on the backplane. This can be just a wire jumper or it can be a fuse. If you use a wire jumper, you need to fuse the logic power supply somewhere before the backplane.

Figures 1 through 7 show the backplane power jumper locations, which are not clearly marked on the backplane. Install only one jumper at a time. If you install both jumpers, you can damage the supply or SSR module backplane.

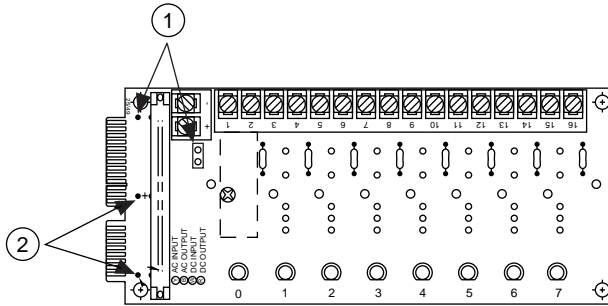

Note: No External Power Jumper Locations, remove all DAQ device power jumpers for external power connection.

1 DAQ Device Power Jumper Location (use only one) 2 Not Used

Figure 1. Grayhill 8 Module Backplane Jumper Locations

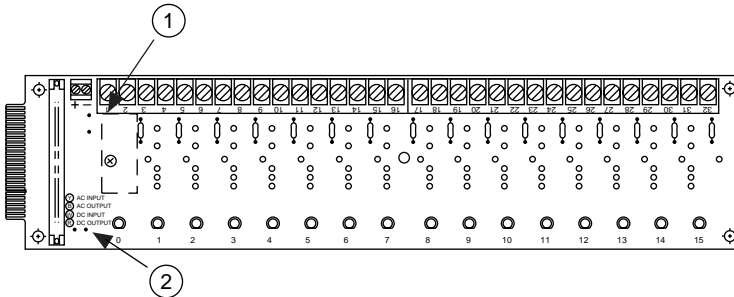

Note: No External Power Jumper Locations, remove all DAQ device power jumpers for external power connection.

1 DAQ Device Power Jumper Location 2 Not Used

Figure 2. Grayhill 16 Module Backplane Jumper Locations

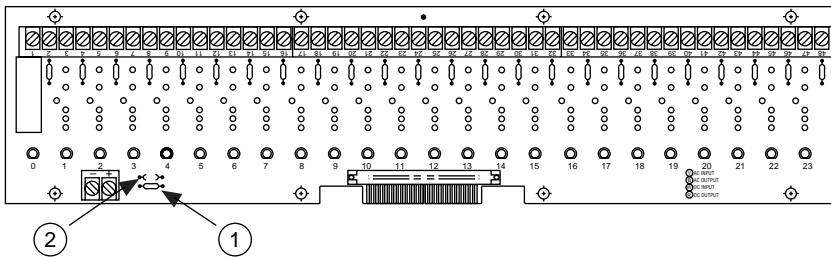

1 External Power Jumper 2 DAQ Device Power Jumper

Figure 3. Grayhill 24 Module Backplane Jumper Locations

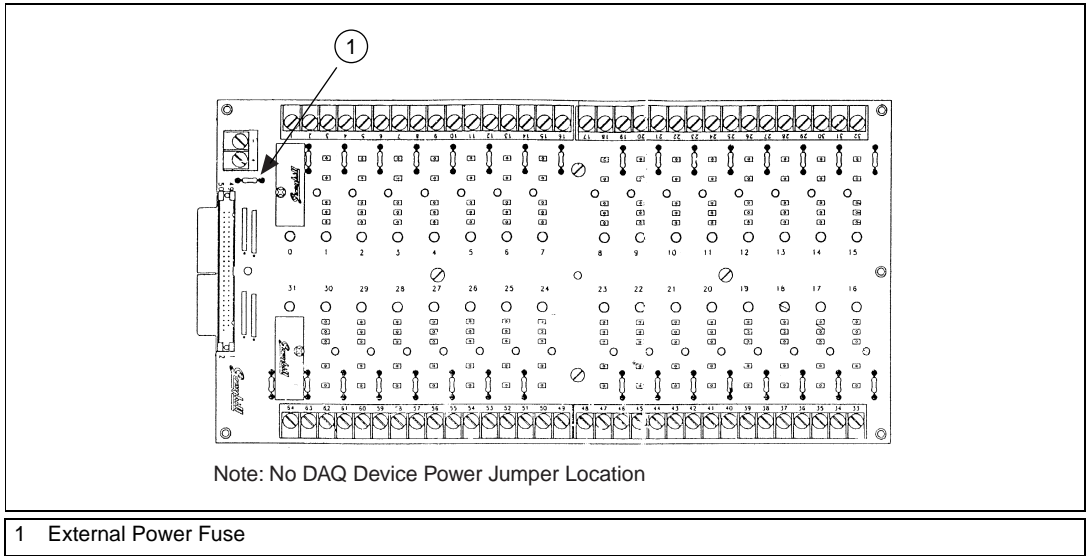

Figure 4. Grayhill 32 Module Backplane Jumper Locations



Note

The Grayhill 32-module backplane can be powered only by an external power supply. There are no jumper settings. There is a fuse on the external power supply.

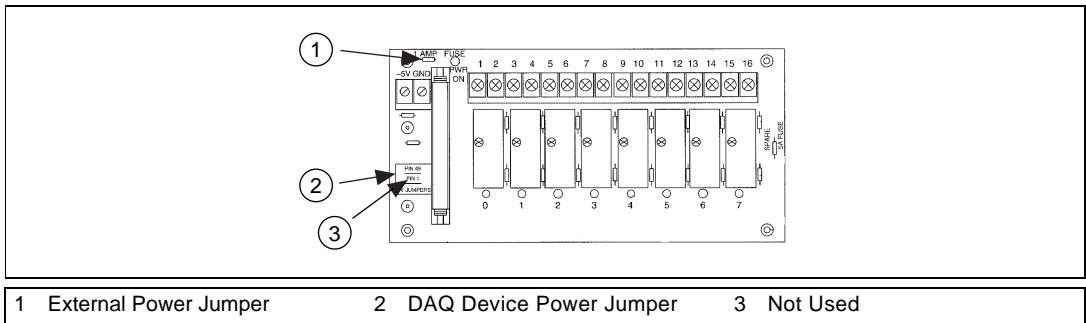

Figure 5. Crouzet 8 Module Backplane Jumper Locations

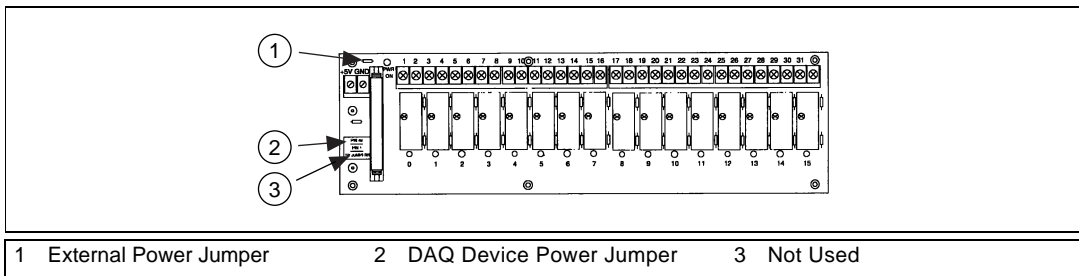

Figure 6. Crouzet 16 Module Backplane Jumper Locations

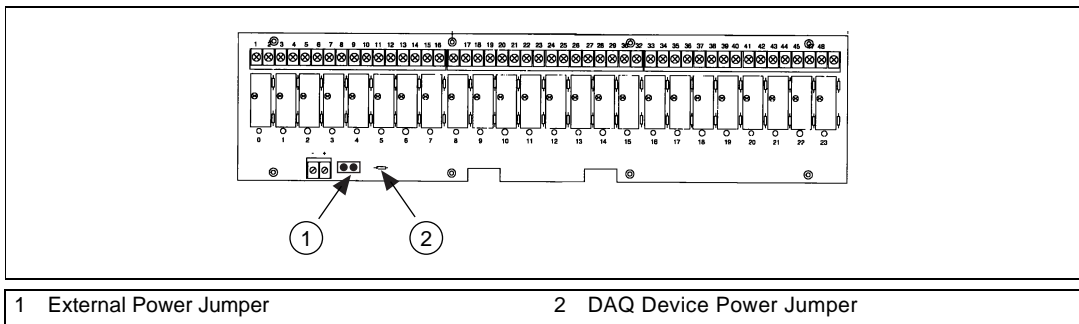

Figure 7. Crouzet 24 Module Backplane Jumper Locations



Note

The Crouzet 32 module backplane has no position on the backplane for either a fuse or jumper. You must add a power supply fuse elsewhere before connecting the power. Use a fuse that is suitable for your application.

SSR Module Installation

You can install the SSR modules by plugging each module into one of the positions on an SSR backplane. They are keyed so they cannot be inserted incorrectly. Many DAQ devices require that all DIO lines in a port be configured either for input or output. In these cases make sure you install the same type of SSR module, input or output, for each line in the port.

You can mix input and output SSR modules on the mounting rack only if you connect them to different I/O ports or you use a DAQ device that allows mixed line directions within a port. *Do not* attach input modules to output lines under any circumstances or you can damage the SSR modules or the DAQ device.

LEDs

Each module position of an SSR backplane has a status LED to show the status of the SSR module logic line. For input modules, the LED is on when the load voltage is within the specified range of the SSR module. For the

output modules the LED is on when the module is turned on. See the [Manufacturer Data Sheets](#) section for further information.

Signal Connections

Connect external devices to the SSR modules using the screw terminals. Two screw terminals are dedicated to each module. Screw terminal pair 1 and 2 are for module 0, terminal pair 3 and 4 are for module 1, and so on. In the case of the DC modules, the odd numbered screw terminal is always the positive terminal and the even numbered screw terminal is the negative terminal. On the load side, a 5 A fuse protects each module. This fuse is always located on the even numbered or negative screw terminal to the module. Figures 8 through 11 show typical signal connections. See the [Manufacturer Data Sheets](#) section for further information.

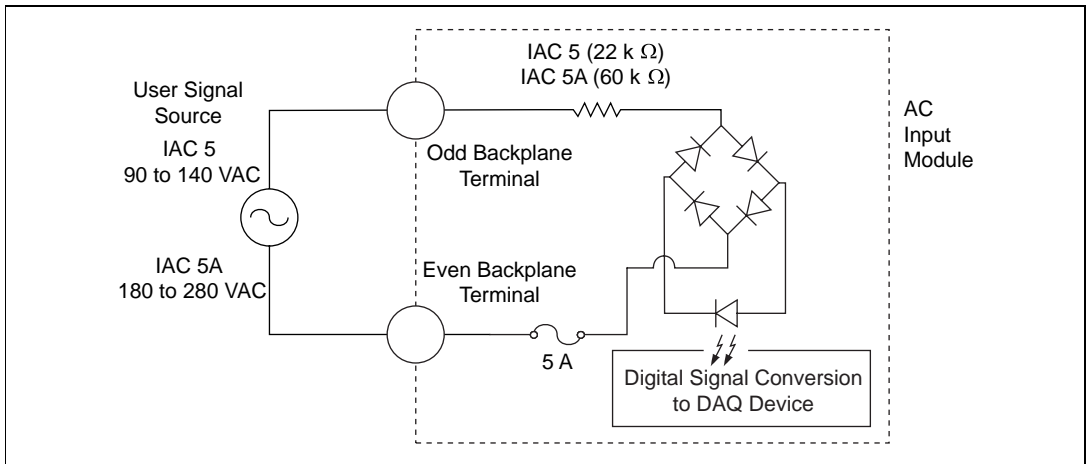

Figure 8. IAC5 and IAC5A Signal Connections

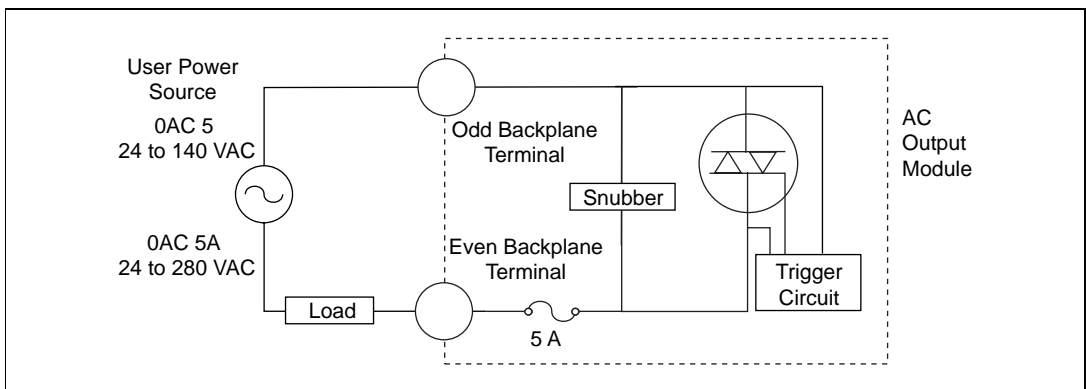

Figure 9. OAC5 and OAC5A Signal Connections

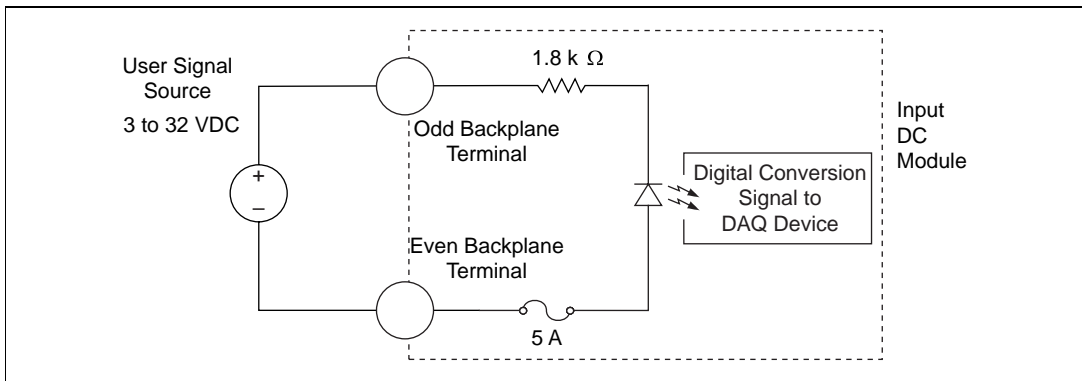

Figure 10. IDC5 Signal Connections

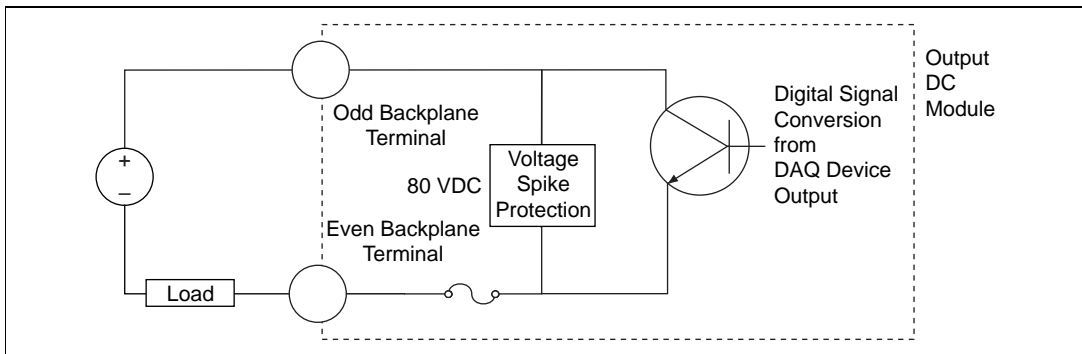

Figure 11. ODC5 Signal Connections

Manufacturer Data Sheets

This section contains the manufacturing data sheets of Grayhill Corporation¹ and Crouzet Corporation².

The Grayhill data sheets include the 70-OAC5 and 70-OAC5A AC output modules; 70-ODC5 DC output module; 70-IAC5 and 70-IAC5A AC input modules; 70-IDC DC input module; and 70-RCK8, 70-RCK16, 70-RCK24, and 70-RCK32-HL mounting racks.

The Crouzet data sheets include the IAC5, IAC5A, and IAC 0.6 in. digital input modules; OAC5, OAC5A, and ODC 0.6 in. digital output modules; and PB-8H, PB-16H, PB-24, and PB-32D 0.6 in. digital I/O mounting boards.

¹ Copyright © Grayhill, Inc. 1998. Reprinted with permission of the copyright owner. All rights reserved. Grayhill, Inc. *Grayhill Control Products Catalog #7*

² Copyright © Crouzet, Inc. 1996. Reprinted with permission of the copyright owner. All rights reserved. Crouzet, Inc. *1998/1999 Automation Controls Catalog*

AC OUTPUT MODULES



70G-OAC

70-OAC

70M-OAC

FEATURES

- Transient Protection: Meets the requirements of IEEE 472, "Surge Withstanding Capability Test"
- SPST, Normally Open
- Zero Crossing Turn-On
- UL Recognized, CSA Certified
- G5 Modules Passed IEC801.2, IEC801.3, and IEC801.4
- 4000 Vac Optical Isolation
- G5 Modules Provide Replaceable 5 x 20 mm Glass Fuse and Built-in Status LED
- Lifetime Warranty

CIRCUITRY

Fuse and Status LED in G5 modules only.

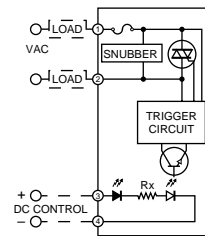

Trigger circuit provides zero voltage turn-on except for part numbers 70-OAC5A5 and 70-OAC5A-11, which have random (fast) turn-on.

Maximum Current Versus Ambient Temperature

The chart indicates continuous current to limit the junction temperatures to 100°C. Information is based on steady state heat transfer in a 2 cubic foot sealed enclosure.

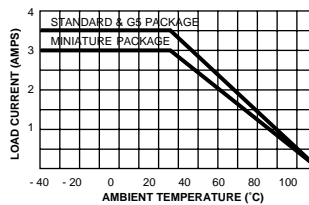

Figure 1

Maximum Peak Surge Current Versus Surge Duration

Information is based on a supply frequency of 60 Hz sinusoidal and a resistive or inductive load. Application of maximum surge current may not be repeated until the module temperature has returned to its steady state value.

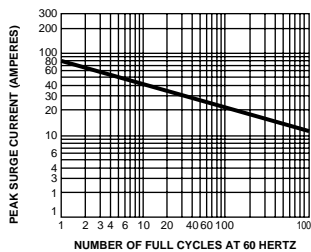

Figure 2

DIMENSIONS

For complete dimensional drawings, see pages 29-30.

G5 FUSES

Fuses are 5 Amp Littlefuse part number 217005 or equivalent.

- *Part Numbers:
- 70G-OAC5
 - 70G-OAC5A
 - 70G-OAC5A-11
 - 70G-OAC15
 - 70G-OAC15A
 - 70G-OAC24
 - 70G-OAC24A

AC OUTPUT MODULES

SPECIFICATIONS--All Modules Specifications apply over operating temperature range unless noted otherwise.

Output Specifications

Load Current Range (rms): 0.03 to 3.5 Amps for part numbers beginning 70 and 70G. 0.03 to 3.0 Amps for part numbers beginning 70M. Maximum current is limited by data noted in Figure 1.

Maximum Surge Current (peak): 80 Amps at 60 Hz, 1 cycle; 25 Amps at 60Hz, 60 cycles as qualified by Figure 2.

Maximum Zero Voltage Offset: $8 V_{peak}$

Static dV/dt: 3000 volts per microsecond typical, measured under open circuit conditions; not to exceed peak blocking voltage.

Turn-on Time (60 Hz): 8.3 mSec maximum (except 70-OAC5A5 which is 200 μ Sec and 70-OAC5A-11, 70M-OAC5A-11 and 70G-OAC5A-11 which are 100 μ Sec)

Turn-off Time (60 Hz): 8.3 mSec maximum

On State Voltage Drop (peak): 1.5 volts max.

Power Dissipation: 1.0 Watt/Amp typical

Load Power Factor: 0.4 minimum

Frequency Range: 25 to 70 Hz

Thermal Resistance (R_{th}): 25° C/Watt typical
I²t for Fusing (t = 8.3 mS): 35 A² per Sec min.

Mechanical Shock: 1500 G?s 0.5 mS half-sine per MIL-STD-202, Method 213, Condition F

Storage Temperature Range:
-40°C to +125°C

Operating Temperature Range:
-40°C to +100°C

Materials and Finishes

Terminals: Copper wire, tin plated
Case: Solvent resistant thermoplastic; meets UL94V-0
Potting: High thermal conductive epoxy

UL Recognition and CSA Certification

UL file number E58632 and CSA file number LR38763 apply to all modules shown here.

General Characteristics

Insulation Resistance (Input to Output;

Input or Output to Case): $\geq 10^{10}$ Ohms

Dielectric Strength Input to Output:

4000 Vac (rms) minimum

Input to Output Capacitance: 6 pF typical

Vibration: 20 G?s peak or .06" double amplitude 10-2000 Hz per MIL-STD-202, Method 204, Condition D

SPECIFICATIONS BY PART NUMBER

Standard and Miniature Modules

Type/Function		Grayhill Part Number					
Miniature, Normally Open, Random Turn-on			70M-OAC5A-11				
Miniature, Normally Open, Zero Voltage Turn-on		70M-OAC5	70M-OAC5A	70M-OAC15	70M-OAC15A	70M-OAC24	70M-OAC24A
Standard, Normally Closed, Random Turn-on			70-OAC5A5				
Standard, Normally Open, Random Turn-on			70-OAC5A-11				70-OAC24A-11
Standard, Normally Open, Zero Voltage Turn-on		70-OAC5	70-OAC5A	70-OAC15	70-OAC15A	70-OAC24	70-OAC24A
Specifications	Units						
Nominal Line Voltage	Vac	120	240	120	240	120	240
Load Voltage Range	Vac	24-140	24-280	24-140	24-280	24-140	24-280
Minimum Peak Blocking Voltage	Volts	400	600	400	600	400	600
Maximum Off-state Leakage @ 60Hz.	mA, rms	2	4	2	4	2	4
Nominal Logic Voltage (Vcc)	Vdc	5	5	15	15	24	24
Logic Voltage Range	Vdc	2.5-10	2.5-10	10-18	10-18	15-30	15-30
Max. Logic Supply Current @ Nominal Vcc	mA	16	16	9	9	9	9
Nominal Input Resistance (Rx)	Ω	240	240	1800	1800	2700	2700
Minimum Drop Out Voltage	Vdc	1	1	1	1	1	1
Maximum Reverse Logic Voltage	Vdc	-5	-5	-5	-5	-5	-5

G5 Modules

Type/Function		Grayhill Part Number					
G5 Fusible, Normally Open, Zero Voltage Turn-on		70G-OAC5	70G-OAC5A	70G-OAC15	70G-OAC15A	70G-OAC24	70G-OAC24A
G5 Fusible, Normally Open, Random Turn-on			70G-OAC5A-11				
Specifications	Units						
Nominal Line Voltage	Vac	120	240	120	240	120	240
Load Voltage Range	Vac	24-140	24-280	24-140	24-280	24-140	24-280
Minimum Peak Blocking Voltage	Volts	400	600	400	600	400	600
Maximum Off-state Leakage @ 60Hz.	mA, rms	2	4	2	4	2	4
Nominal Logic Voltage (Vcc)	Vdc	5	5	15	15	24	24
Logic Voltage Range	Vdc	4-6	4-6	8-20	8-20	18-32	18-32
Max. Logic Supply Current @ Nominal Vcc	mA	20	20	12	12	8	8
Nominal Input Resistance (Rx)	Ω	100	100	1000	1000	2700	2700
Minimum Drop Out Voltage	Vdc	1	1	1	1	1	1
Maximum Reverse Logic Voltage	Vdc	-5	-5	-5	-5	-5	-5

Available from your local Grayhill Distributors
For prices and discounts, contact a local Sales Office, an authorized local Distributor, or Grayhill.



561 Hillgrove Avenue • LaGrange, Illinois 60525 • USA • Phone: (708) 354-1040 • Fax: (708) 354-2820 • <http://www.grayhill.com>

DC OUTPUT MODULE



70G-ODC 70-ODC 70M-ODC

SEE CIRCUITRY AND DIMENSIONAL DRAWING FOR TERMINAL ID OF 70-ODC5R AND 70G-ODC5R.

Maximum Current Versus Ambient Temperature

The chart indicates continuous current to limit the junction temperatures to 115°C. Information is based on steady state heat transfer in a 2 cubic foot sealed enclosure.

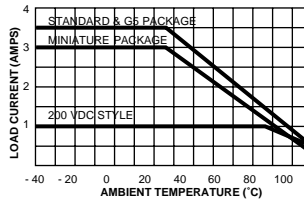

Figure 1

DIMENSIONS

For complete dimensional drawings, see pages 29-30.

G5 FUSES

Fuses are 5 Amp Littlefuse part number 217005 or equivalent.

- *Part Numbers: 70G-ODC5
70G-ODC5A
70G-ODC5B
70G-ODC15
70G-ODC15B
70G-ODC24
70G-ODC24A
70G-ODC24B

FEATURES

- Transient Protection: Meets the requirements of IEEE 472, "Surge Withstanding Capability Test"
- SPST, Normally Open
- UL Recognized, CSA Certified
- G5 Modules Passed IEC801.2, IEC801.3, and IEC801.4
- 4000 Vac Optical Isolation
- G5 Modules Provide Replaceable 5 x 20 mm Glass Fuse and Built-in Status LED
- Lifetime Warranty

CIRCUITRY

Two choices of switching speed vs. leakage current are offered. In applications where both AC and DC must be switched with the same module, use 70-ODC5R, 70M-ODC5R or 70G-ODC5R. These parts are dry contact relays in an I/O module shell. All other part numbers provide solid state switching.

Solid State

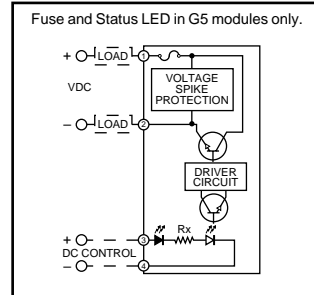

Dry Contact

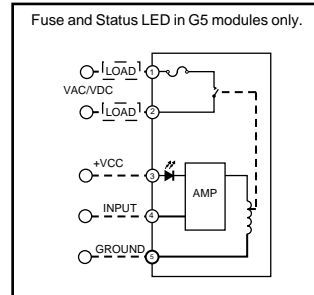

DC OUTPUT MODULES

SPECIFICATIONS Specifications apply over operating temperature range unless noted otherwise.

<p>Output Specifications Load Current Range: 0.02 to 3.5 Amps for part numbers beginning 70 and 70G; 0.02 to 3.0 Amps for 70M modules; 0.02 to 1.0 Amp for 70-ODC5A, 70M-ODC5A and 70G-ODC5A. Maximum current is limited by data noted in Figure 1. Power Dissipation: 1.0 Watt/Amp typical; 1.5 Watt/Amp typ. for 70-ODC5A, 70M-ODC5A and 70G-ODC5A. Surge Current: 5 Amps maximum for 1 second On State Voltage Drop: 1.2 Volts maximum; 1.75 Volts maximum for 70-ODC5A, 70M-ODC5A and 70G-ODC5A. Clamping Voltage: 80 Vdc maximum; 360 Vdc maximum for 70-ODC5A, 70M-ODC5A</p>	<p>and 70G-ODC5A. Thermal Resistance($R_{\theta(jc)}$): 20°C/Watt typical Transient Power Dissipation: 400 Watts at 1 mS non-recurring General Characteristics Insulation Resistance (Input to Output; Input or Output to Case): $\geq 10^{10}$ Ohms Dielectric Strength Input to Output: Solid State: 4000 Vac (rms) minimum Dry Contact: 1500 Vac (rms) minimum Input to Output Capacitance: 10 pF typical Vibration: 20 G's peak or .06" double amplitude 10–2000 Hz per MIL–STD–202, Method 204, Condition D Mechanical Shock: 1500 G's 0.5 mS half-sine per MIL–STD–202, Method 213, Condition F</p>	<p>Storage Temperature Range: -40°C to +125°C Operating Temperature Range: Solid State: -40°C to +100°C Dry Contact: -20°C to +85°C Materials and Finishes Terminals: Copper wire, tin plated Case: Solvent resistant thermoplastic; meets UL94V-0 Potting: High thermal conductive epoxy UL Recognition & CSA Certification UL file number E58632 and CSA file number LR38763 apply to all modules shown here.</p>
---	--	--

SPECIFICATIONS BY PART NUMBER—Solid State Modules Standard and Miniature Modules

Type/Function		Grayhill Part Number						
Miniature, Normally Open		70M-ODC5	70M-ODC5A	70M-ODC5B	70M-ODC15	70M-ODC15B	70M-ODC24	70M-ODC24B
Standard, Normally Open		70-ODC5	70-ODC5A	70-ODC5B	70-ODC15	70-ODC15B	70-ODC24	70-ODC24B
Specifications	Units							
Maximum Line Voltage	Vdc	60	200	60	60	60	60	60
Load Voltage Range	Vdc	3-60	4-200	3-60	3-60	3-60	3-60	3-60
Max. Off-state Leakage @ 60 Vdc	mA	1.5	.010	.010	1.5	0	1.5	.010
Maximum Turn-on Time	µSec	20	75	75	20	20	20	75
Maximum Turn-off Time	µSec	50	750	500	50	50	50	500
Nominal Logic Voltage (Vcc)	Vdc	5	5	5	15	15	24	24
Logic Voltage Range	Vdc	2.5-10	2.5-9	2.5-10	10-18	10-18	15-30	15-30
Max. Logic Supply Current @ Nominal Vcc	mA	14	18	14	9	9	9	9
Nominal Input Resistance (Rx)	Ω	300	220	300	1800	1800	2700	2700
Minimum Drop Out Voltage	Vdc	1	1	1	1	1	1	1
Maximum Reverse Logic Voltage	Vdc	-5	-5	-5	-5	-5	-5	-5

G5 Modules

Type/Function		Grayhill Part Number						
G5 Fusible, Normally Open		70G-ODC5	70G-ODC5A	70G-ODC5B	70G-ODC15	70G-ODC15B	70G-ODC24	70G-ODC24B
Specifications	Units							
Maximum Line Voltage	Vdc	60	200	60	60	60	60	60
Load Voltage Range	Vdc	3-60	4-200	3-60	3-60	3-60	3-60	3-60
Max. Off-state Leakage @ 60 Vdc	mA	1.5	.010	0.01	1.5	0.01	1.5	0.01
Maximum Turn-on Time	µSec	20	75	75	20	75	20	75
Maximum Turn-off Time	µSec	50	750	500	50	500	50	500
Nominal Logic Voltage (Vcc)	Vdc	5	5	5	15	15	24	24
Logic Voltage Range	Vdc	4-6	4-6	4-6	10-20	10-20	18-32	18-32
Max. Logic Supply Current @ Nominal Vcc	mA	13	13	13	9	9	9	9
Nominal Input Resistance (Rx)	Ω	150	150	150	1500	1500	2700	2700
Minimum Drop Out Voltage	Vdc	1	1	1	1	1	1	1
Maximum Reverse Logic Voltage	Vdc	-5	-5	-5	-5	-5	-5	-5

SPECIFICATIONS BY PART NUMBER—Dry Contact Modules 70-ODC5R, 70M-ODC5R and 70G-ODC5R

<p>Output Specifications Load Voltage: 100 Vdc/120 Vac maximum Contact Rating: 10 Watts maximum Switching Current: 0.5 A dc maximum. Inductive loads require diode suppression. Carry Current: 1.0 A maximum. Inductive loads require diode suppression. Life Expectancy: At 10 Vdc: 10 mA-200,000,000 operations min.</p>	<p>At 48 Vdc: 100 mA-500,000 operations min. At 120 Vac: 80 mA-500,000 operations min. Contact Resistance: 250 mΩ maximum Turn-on Time: 1.0 mSec maximum (including bounce) Turn-off Time: 1.0 mSec maximum (including bounce) Off-State Leakage Current: 2 µA maximum at 60 Hz</p>	<p>Input Specifications Nominal Logic Voltage: 5 Vdc Logic Voltage Range: 4.8-6.0 Vdc Max Logic Supply Current at Nominal Voltage: 10 mA Input Resistance: 500 Ω Pick Up Voltage: 0.8 Vdc minimum Drop Out Voltage: 2.5 Vdc minimum Reverse Logic Voltage: 5 Vdc maximum</p>
--	--	---



AC INPUT MODULE



70G-IAC

70-IAC

70M-IAC



FEATURES

- Transient Protection: Meets the requirements of IEEE 472, "Surge Withstanding Capability Test"
- G5 Modules Passed IEC801.2, IEC801.3, and IEC801.4
- UL Recognized, CSA Certified
- 4000 Vac Optical Isolation
- G5 Module has Built-in Status LED
- Lifetime Warranty

Typical Logic Supply Current Versus Logic Supply Voltage

For Figures 1 and 2, all values were measured at 25°C. The logic supply voltage continuum represents the voltage range for each of the three nominal voltages (5, 15, and 24 Vdc).

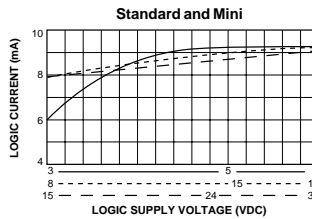

Figure 1

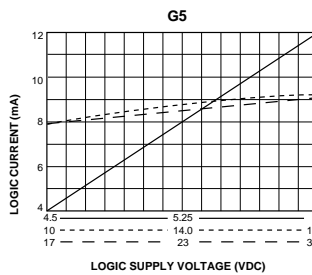
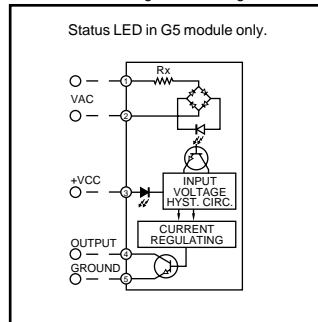

Figure 2

CIRCUITRY Negative True Logic



DIMENSIONS

For complete dimensional drawings, see pages 29-30.

- *Part Numbers:
- 70G-IAC5
 - 70G-IAC5A
 - 70G-IAC15
 - 70G-IAC15A
 - 70G-IAC24
 - 70G-IAC24A

AC INPUT MODULE

SPECIFICATIONS—All Modules Specifications apply over operating temperature range unless noted otherwise.

<p>Output Specifications Output Current Range: 1-50 mA Breakdown Voltage: 50 Vdc minimum Off-State Leakage Current: 1 μA maximum Turn-on Time: 20 mSec maximum Turn-off Time: 20 mSec maximum On State Voltage Drop: 0.45 Vdc at 50 mA maximum</p>	<p>General Characteristics Insulation Resistance (Input to Output; Input or Output to Case): $\geq 10^{10}$ Ohms Dielectric Strength Input to Output: 4000 Vac (rms) minimum Input to Output Capacitance: 6 pF typical Vibration: 20 G?s peak or .06" double amplitude 10–2000 Hz per MIL–STD–202, Method 204, Condition D Mechanical Shock: 1500 G?s 0.5 mS half-sine per MIL–STD–202, Method 213, Condition F Storage Temperature Range: –40° C to +125° C Operating Temperature Range: –40° C to +100° C</p>	<p>Materials and Finishes Terminals: Copper wire, tin plated Case: Solvent resistant thermoplastic; meets UL94V–0 Potting: High thermal conductive epoxy</p> <p>UL Recognition and CSA Certification UL file number E58632 and CSA file number LR38763 apply to all modules shown here.</p>
--	---	--

SPECIFICATIONS BY PART NUMBER

Type/Function		Grayhill Part Number					
		70G-IAC5	70G-IAC5A	70G-IAC15	70G-IAC15A	70G-IAC24	70G-IAC24A
Miniature		70M-IAC5	70M-IAC5A	70M-IAC15	70M-IAC15A	70M-IAC24	70M-IAC24A
Standard		70-IAC5	70-IAC5A	70-IAC15	70-IAC15A	70-IAC24	70-IAC24A
Specifications	Units						
Nominal Input Voltage	Vac	120	240	120	240	120	240
Input Voltage Range*	Vac/Vdc	90-140	180-280	90-140	180-280	90-140	180-280
Input Current at Maximum Input Voltage	mA, rms	8	6	8	6	8	6
Nominal Input Resistance (Rx)	Ω	22K	60K	22K	60K	22K	60K
Maximum Pick Up Voltage (Output Low)	Vac	90	180	90	180	90	180
Minimum Drop Out Voltage (Output High)	Vac	25	50	25	50	25	50
Nominal Logic Voltage (Vcc)	Vdc	5	5	15	15	24	24
Logic Voltage Range: Standard and Mini	Vdc	3-6	3-6	8-18	8-18	15-30	15-30
G5	Vdc	4.5-6	4.5-6	10-18	10-18	17-30	17-30
Max. Logic Supply Current @ Nominal Vcc (See Figure 1 or 2)	mA	10	10	10	10	10	10

* For input voltages in the range of 15-32 Vac, or 35-60 Vac, see DC input Modules with the NP or G suffix.

Available from your local Grayhill Distributors
 For prices and discounts, contact a local Sales Office, an authorized local Distributor, or Grayhill.



561 Hillgrove Avenue • LaGrange, Illinois 60525 • USA • Phone: (708) 354-1040 • Fax: (708) 354-2820 • <http://www.grayhill.com>

DC INPUT MODULE



70G-IDC

70-IDC

70M-IDC



FEATURES

- Transient Protection: Meets the requirements of IEEE 472, "Surge Withstanding Capability Test"***
- Fast Switching Polarized Input Types
- Non-Polarized Types Provide Inputs For AC or DC
- UL Recognized, CSA Certified
- G5 Modules Passed IEC801.2, IEC801.3, and IEC801.4
- 4000 Vac Optical Isolation
- G5 Module has Built-in Status LED
- Lifetime Warranty

**All modules except 70-IDC5B, 70G-IDC5B, and 70G-IDC5D meet IEEE 472, "Surge Withstanding Capability Test"

Typical Logic Supply Current Versus Logic Supply Voltage

For Figures 1 and 2, all values were measured at 25° C. The logic supply voltage continuum represents the voltage range for each of the three nominal voltages (5, 15, and 24 Vdc).

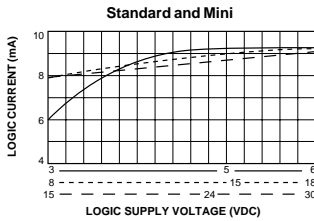

Figure 1

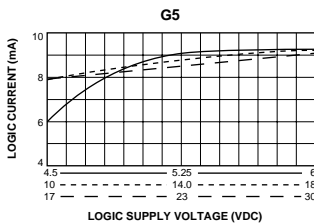

Figure 2

DIMENSIONS

For complete dimensional drawings, see pages 29-30.

*Part Numbers:	70G-IDC5	70G-IDC15
	70G-IDC5B	70G-IDC15NP
	70G-IDC5G	70G-IDC24
	70G-IDC5NP	70G-IDC24NP
	70G-IDC5S	

CIRCUITRY Negative True Logic

Modules have either a polarized (Figure 3) or non-polarized (Figure 4) input. When replacing modules from another manufacturer, check the wiring diagrams below against the application circuit. In many instances, polarized modules can be used to replace non-polarized modules if the polarity matches the application, thus providing faster turn-on.

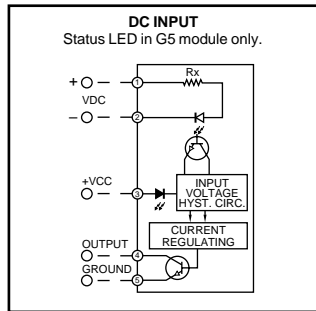

Figure 3: With Polarized Input

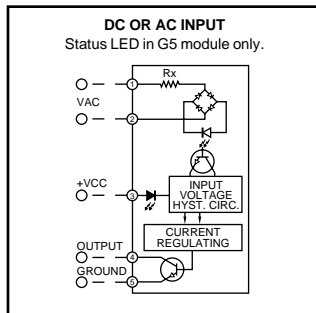

Figure 4: With Non-Polarized (NP) Input

DC INPUT MODULE

SPECIFICATIONS—All Modules Specifications apply over operating temperature range unless noted otherwise.

Output Specifications Output Current Range: 1-50 mA Breakdown Voltage: 50 Vdc minimum Off State Leakage Current: 1 μ A maximum On State Voltage Drop: 0.45 Vdc at 50 mA maximum Storage Temperature Range: -40°C to +125°C Operating Temperature Range: -40°C to +100°C	General Characteristics Insulation Resistance (Input to Output; Input or Output to Case): $\geq 10^9$ Ohms Dielectric Strength Input to Output: 4000 Vac (rms) minimum Input to Output Capacitance: 6 pF typical Vibration: 20 G's peak or .06" double amplitude 10–2000 Hz per MIL–STD–202, Method 204, Condition D Mechanical Shock: 1500 G's 0.5 mS half-sine per MIL–STD–202, Method 213, Condition F	Materials and Finishes Terminals: Copper wire, tin plated Case: Solvent resistant thermoplastic; meets UL94V–0 Potting: High thermal conductive epoxy UL Recognition & CSA Certification UL file number E58632 and CSA file number LR38763 apply to all modules shown here, except 70-IDC5B and 70M-IDC5NP.
--	--	---

SPECIFICATIONS—By Part Number (DC Input Only)

Type/Function		Grayhill Part Number					
		70G-IDC5	70G-IDC5B	70G-IDC5D	70G-IDC5K	70G-IDC15	70G-IDC24
Miniature, Polarized		70M-IDC5				70M-IDC15	70M-IDC24
Standard, Polarized		70-IDC5	70-IDC5B			70-IDC15	70-IDC24
Specifications	Units						
Maximum Input Voltage	Vdc	32	32	28	16	32	32
Input Voltage Range*	Vdc	3-32	3-32	2.5-28	2.5-16	3-32	3-32
Input Current at Max. Input Voltage	mA	18	18	23	30	18	18
Maximum Turn-on Time	mSec	0.20	0.050	0.050	0.025	0.20	0.20
Maximum Turn-off Time	mSec	0.40	0.075	0.075	0.125	0.40	0.40
Nominal Input Resistance (Rx)	Ω	1.8K	1.8K	1.2K	500	1.8K	1.8K
Max. Pick Up Voltage (Output Low)	Vdc	3	3	2.5	2.5	3	3
Min. Drop Out Voltage (Output High)	Vdc	1	1	1	1	1	1
Nominal Logic Voltage (Vcc)	Vdc	5	5	5	5	15	24
Logic Voltage Range: Std & Mini	Vdc	3-6	3-6			8-18	15-30
G5	Vdc	4.5-6	4.5-6	4.5-6	4.5-6	10-18	17-30
Max. Logic Supply Current @ Nominal Vcc (See Figure 1 or 2)	mA	10	18	10	18	10	10

SPECIFICATIONS—By Part Number (AC or DC Input)

Type/Function		Grayhill Part Number			
		70G-IDC5G	70G-IDC5NP	70G-IDC15NP	70G-IDC24NP
Miniature, Non-Polarized		70M-IDC5G	70M-IDC5NP		
Standard, Non-Polarized		70-IDC5G	70-IDC-5NP	70-IDC15NP	70-IDC24NP
Specifications	Units				
Maximum Input Voltage	Vac/Vdc	60	32	28	32
Input Voltage Range*	Vac/Vdc	35-60	15-32	15-32/10-32	15-32/10-32
Input Current at Max. Input Voltage	mA	6	5	25	25
Maximum Turn-on Time	mSec	10	5	5	5
Maximum Turn-off Time	mSec	10	5	5	5
Nominal Input Resistance (Rx)	Ω	1.8K	1.8K	1.8K	1.8K
Max. Pick Up Voltage (Output Low)	Vac/Vdc	3	15/10	15/10	15/10
Min. Drop Out Voltage (Output High)	Vac/Vdc	9	3	3	3
Nominal Logic Voltage (Vcc)	Vdc	5	5	15	24
Logic Voltage Range: Std & Mini	Vdc	3-6	3-6	8-18	15-30
G5	Vdc	4.5-6	4.5-6	10-18	17-30
Max. Logic Supply Current @ Nominal Vcc (See Figure 1 or 2)	mA	10	10	10	10

* For input voltages in the range of 90 to 140 Vdc, use AC input modules 70-IAC5, 70M-IAC5 or 70G-IAC5. For input voltages in the range of 180 to 280 Vdc, use AC input modules 70-IAC5A, 70M-IAC5A or 70G-IAC5A.

Available from your local Grayhill Distributors
 For prices and discounts, contact a local Sales Office, an authorized local Distributor, or Grayhill.



DIGITAL I/O MODULES

0.6 INCH INPUT MODULES

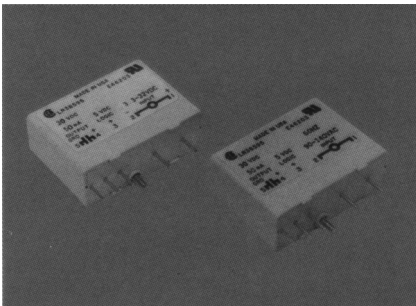

FEATURES:

- CE Compliant
- Plug into Mounting Boards for 0.6" Modules
- AC Inputs for 24 V, 120 V, 240 V
- DC Inputs for 3.3 to 32 V, 10 to 48 V
- UL Recognized (E46203) / CSA Certified (38595)
- 4 kV Optical Isolation
- Open-Collector Output
- Industry Standard Packaging

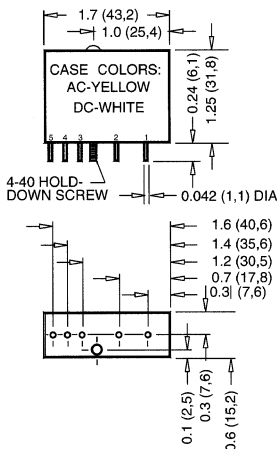

DIMENSIONS: INCHES (MILLIMETERS)
TOLERANCE: ±0.020 (±0.50)

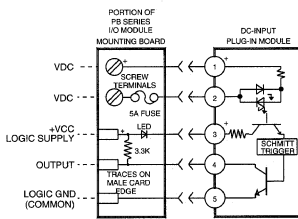
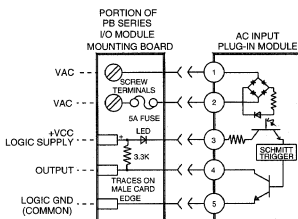

(EQUIVALENT CIRCUIT DIAGRAMS)

Products and specifications subject to change without notice.
Consult factory for application assistance.

3237 Commander, Carrollton, Texas 75006 / Tel: (972) 250-1647 / (800) 677-5311 / FAX: (972) 250-3865



DIGITAL I/O MODULES

0.6 INCH INPUT MODULES

INPUT SPECIFICATIONS: (1)

Model Number	IAC5 IAC24	IAC5A IAC24A	IDC5 IDC24	IDC5F IDC24F	IDC5N IDC24N
Parameter					
Nominal Voltage	120 VAC	240 VAC	5-28 VDC	5-28 VDC	12-48 VDC
Maximum Voltage	140 VAC/VDC	280 VAC/VDC	32 VDC/VAC	32 VDC	48 VDC/VAC
Minimum Voltage	90 VAC/VDC	180 VAC/VDC	3.3 VDC/VAC	4.0 VDC	10 VDC/VAC
Resistance (2) (3)	28 kΩ	75 kΩ	1 kΩ	500 Ω	2.7 kΩ
Maximum Current (4)	6 mArms	5 mArms	34 mA	68 mA	34 mA
Drop-out Current (5)	2.0 mArms	1.5 mArms	1.0 mA	1.0 mA	1.0 mA
Allowable Current/ Voltage for No Output (6)	2.5 mArms 50 VAC/VDC	2.0 mArms 50 VAC/VDC	1.5 mA 2.0 VDC	1.5 mA 2.0 VDC	1.5 mA 4.0 VDC

OUTPUT SPECIFICATIONS: (1)

Model Number	IAC5 IAC5A IDC5 IDC5F IDC5N	IAC24 IAC24A IDC24 IDC24F IDC24N	Units
Parameter			
Nominal Logic Supply Voltage	5.0	24.0	VDC
Maximum Logic Supply Voltage	6.0	30.0	VDC
Minimum Logic Supply Voltage	3.0	20.0	VDC
Maximum Logic Supply Current (7)	16.0	16.0	mA
Maximum Logic Supply Leakage Current (8)	10.0	10.0	μA
Maximum Voltage (9)	30.0	30.0	VDC
Maximum Current (10)	50.0	50.0	mA
Maximum Leakage Current (11)	10.0	10.0	μA
Maximum Voltage Drop (12)	0.2	0.2	VDC

GENERAL SPECIFICATIONS: (1)

Model Number	IAC5, IAC5A, IAC24, IAC24A	IDC5 IDC24	IDC5F IDC24F	IDC5N IDC24N	Units
Parameter					
Operating Temperature Range	-30 to 80	-30 to 80	-30 to 80	-30 to 80	°C
Storage Temperature Range	-40 to 100	-40 to 100	-40 to 100	-40 to 100	°C
Maximum Turn-on Time (13)	20	1.0	0.05	8.0	mSec
Maximum Turn-off Time (13)	20	1.0	0.10	7.0	mSec
Input/Output Isolation Voltage (14)	4000	4000	4000	4000	VAC
Input/Output Capacitance (typical)	8	8	8	8	pF
Line Frequency Range	47 to 63	DC	DC	DC	Hertz
Weight	1.1 oz	1.1 oz	1.1 oz	1.1 oz	

TABLE OF MODEL NUMBER SUFFIXES IDENTIFYING OPTIONAL FEATURES

Suffix	Feature
A	High voltage versions (240 VAC for AC modules).
F	Fast-switching version of DC Modules.
N	Enhanced noise immunity version of DC modules.

Notes:

- (1) Specifications apply to an ambient temperature of -30 to 80°C unless otherwise noted.
- (2) Resistance values for IAC modules are effective impedance values at 25°C.
- (3) Resistance values are ±10% at 25°C.
- (4) Measured at maximum specified input voltage, 25°C.
- (5) Defined as the maximum current allowed through the module's input to guarantee that the output will switch from "on" to "off." Higher currents may result in the output remaining in the "on" state.
- (6) Defined as the maximum current allowed through the module's input that will not switch the module's output state from "off" to "on."
- (7) With external LED status indicator at maximum specified logic supply voltage and 25°C.
- (8) At maximum specified logic voltage and 25°C.
- (9) Maximum allowable applied voltage across open collector output transistor.
- (10) Maximum allowable sinking current through open collector output transistor.
- (11) At maximum output voltage and 25°C.
- (12) At maximum allowable output current and 25°C.
- (13) At nominal logic supply voltage, 25 mA output sinking current, nominal input voltage and 25°C.
- (14) At 25°C for 1 second maximum duration.

Products and specifications subject to change without notice.

Consult factory for application assistance.

3237 Commander, Carrollton, Texas 75006 / Tel: (972) 250-1647 / (800) 677-5311 / FAX: (972) 250-3865

2-5

DIGITAL I/O MODULES

0.6 INCH OUTPUT MODULES

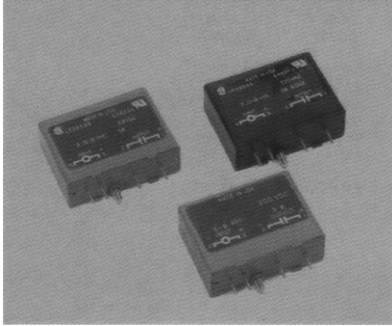

FEATURES:

- CE Compliant
- UL Recognized/Horse Power Rated (E46203)/CSA Certified (38595)
- AC Modules have High Current Thyristor with 100 Amp Surge Capability
- Zero or Random Turn-On Available in AC Modules
- Plug into Mounting Boards for 0.6" Modules
- 4 kV Optical Isolation (1500 VAC Optical Isolation for FET DC Output Modules)
- Industry Standard Packaging
- 3.5 Amp AC Modules Provide Extra Switching Capability
- Form "A" Output
- 5.0 Amp AC(OAC5AH) and DC Modules Available

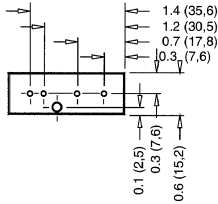
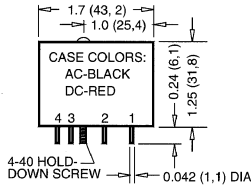

DIMENSIONS: INCHES (MILLIMETERS)
TOLERANCE: ±0.020 (±0.50)

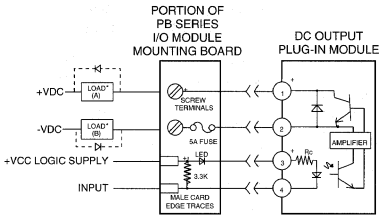
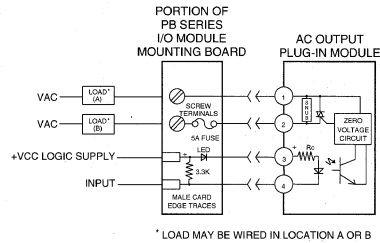

DERATING CURVE FOR OAC5AH ONLY:

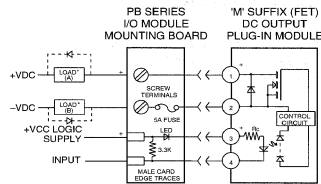
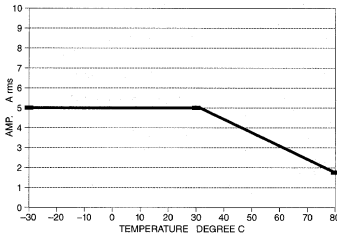

(EQUIVALENT CIRCUIT DIAGRAMS)

Products and specifications subject to change without notice.
Consult factory for application assistance.

3237 Commander, Carrollton, Texas 75006 / Tel: (972) 250-1647 / (800) 677-5311 / FAX: (972) 250-3865



DIGITAL I/O MODULES

0.6 INCH OUTPUT MODULES

INPUT SPECIFICATIONS: (1)

Model Number	OAC5 OAC5A OAC5AH OAC5AR OAC5R	ODC5 ODC5A ODC5F ODC5MA ODC5MC ODC5ML	OAC24 OAC24A ODC24 ODC24A ODC24F	Units
Nominal Voltage	5.0	5.0	24.0	VDC
Minimum Voltage (2)	2.75	2.75	18.0	VDC
Maximum Voltage	8.0	8.0	32.0	VDC
Drop-Out Voltage	1.0	1.0	1.0	VDC
Maximum Current (3)	20.0	18.0	13.0	mA
Resistance (4)	220	250	2000	Ohms

OUTPUT SPECIFICATIONS: (1)

Model Number	OAC5 OAC5R OAC24	OAC5A OAC5AR OAC24A	OAC5AH	ODC5 ODC24	ODC5A ODC24A	ODC5F ODC24F	ODC5MA	ODC5MC	ODC5ML
Nominal Line Voltage	120 VAC	240 VAC	240 VAC	5-48 V	5-150 V	5-48 V	5-150 V	5-90 V	5-48 V
Minimum Line Voltage	12 VAC	24 VAC	24 VAC	3.0 V	3.0 V	3.0 V	1.0 V	1.0 V	1.0 V
Maximum Line Voltage	140 VAC	280 VAC	280 VAC	60 V	250 V	60 V	200 V	100 V	50 V
Max Off-State Voltage (5)	400 Vpeak	600 Vpeak	600 Vpeak	60 V	250 V	60 V	200 V	100 V	50 V
Max Off-State Leakage (6)	3.0 mArms	6.0 mArms	6.0 mArms	10 µA	10 µA	10 µA	10 µA	10 µA	10 µA
Static Off-State dv/dt (7)	200 V / µsec	200 V / µsec	200 V / µsec	N/A	N/A	N/A	N/A	N/A	N/A
Maximum Rated On-State Current (8)	3.5 Arms	3.5 Arms	5.0 A	3.0 A	1.0 A	3.0 A	3.0 A	5.0 A	5.0 A
Minimum On-State Current	50 mArms	50 mArms	50 mArms	10 mA	10 mA	10 mA	1.0 mA	1.0 mA	1.0 mA
Maximum Surge Current (9)	100 Apeak	100 Apeak	100 Apeak	5.0 A	5.0 A	5.0 A	10 A	10 A	10 A
On-State Voltage Drop or Resistance (10)	1.6 V	1.6 V	1.6 V	1.5 V	1.5 V	1.5 V	0.25 Ω	0.10 Ω	0.05 Ω
H.P. Rating (13)	1/8 H.P.	1/3 H.P.	1/2 H.P.	N/A	N/A	N/A	N/A	N/A	N/A

GENERAL SPECIFICATIONS: (1)

Model Number	OAC5 OAC5A OAC5AH OAC24 OAC24A	OAC5R OAC5AR	ODC5 ODC5A ODC24 ODC24A	ODC5F ODC24F	ODC5MA ODC5MC ODC5ML	Units
Operating Temperature Range	-30 to 80	-30 to 80	-30 to 80	-30 to 80	-30 to 80	°C
Storage Temperature Range	-40 to 100	-40 to 100	-40 to 100	-40 to 100	-40 to 100	°C
Maximum Turn-on Time (11)	8.33	0.1	0.1	0.025	1.0	mSec
Maximum Turn-off Time (11)	8.33	8.33	0.75	0.05	0.05	mSec
Input/Output Isolation Voltage (12)	4000	4000	4000	4000	1500	VAC
Input/Output Capacitance (typical)	8	8	8	8	8	pF
Line Frequency Range	47 to 63	47 to 63	DC	DC	DC	Hertz
Weight	1.1 oz	1.1 oz	1.1 oz	1.1 oz	1.1 oz	

TABLE OF MODEL NUMBER SUFFIXES IDENTIFYING OPTIONAL FEATURES

Suffix	Feature
A	High voltage versions (240 VAC for AC modules, 250 VDC for DC modules).
AH	High voltage AC, 5 Amps.
F	Fast-switching version of ODC modules.
MA	FET output version of DC module, 3.0 A, 200 VDC.
MC	FET output version of DC module, 5.0 A, 100 VDC.
ML	FET output version of DC module, 5.0 A, 50 VDC.
R	Random AC voltage turn-on.

Notes:

- (1) Specifications apply to an ambient temperature of -30 to 80°C unless otherwise noted.
- (2) Without external LED status indicator. Add 1.7 volt for external LED if utilized.
- (3) At nominal input voltage, without external LED status indicator.
- (4) ±10% at 25°C.
- (5) Maximum 1 minute duration for OAC modules when applied as a DC voltage rather than peak AC voltage.
- (6) At maximum line voltage, 25°C for OAC modules, and 80°C for ODC modules.
- (7) Minimum dv/dt per EIA/NARM RS443, method RS397. dv/dt ratings do not apply to ODC modules.
- (8) At 40°C, derate OAC modules by 58 mA/°C to 80°C; derate ODC, ODC5MC and ODC5ML modules by 50 mA/°C to 80°C; derate ODC5MA modules by 30 mA/°C to 80°C. CSA rating of OAC modules is 3.0 Arms at 40°C.
- (9) At 25°C. Maximum duration: 1 AC cycle for OAC modules, 1 second for ODC modules.
- (10) At maximum rated on-state current and 25°C.
- (11) At maximum line voltage, maximum rated output current, nominal input voltage, 25°C. Switching speed of OAC modules based upon 60 Hz line frequency.
- (12) At 25°C for 1 second maximum duration.
- (13) 1/3 H.P. at 240 VAC, 1/8 H.P. at 120 VAC.

Products and specifications subject to change without notice.
Consult factory for application assistance.

3237 Commander, Carrollton, Texas 75006 / Tel: (972) 250-1647 / (800) 677-5311 / FAX: (972) 250-3865

2-7

MOUNTING RACKS



8 MODULE RACK—Standard

Part No. 70RCK8

Schematic and Ordering Information on page 54.
 Dimensions are shown in inches (and millimeters).
 All tolerances are ± 0.010 (0,25) unless otherwise specified.

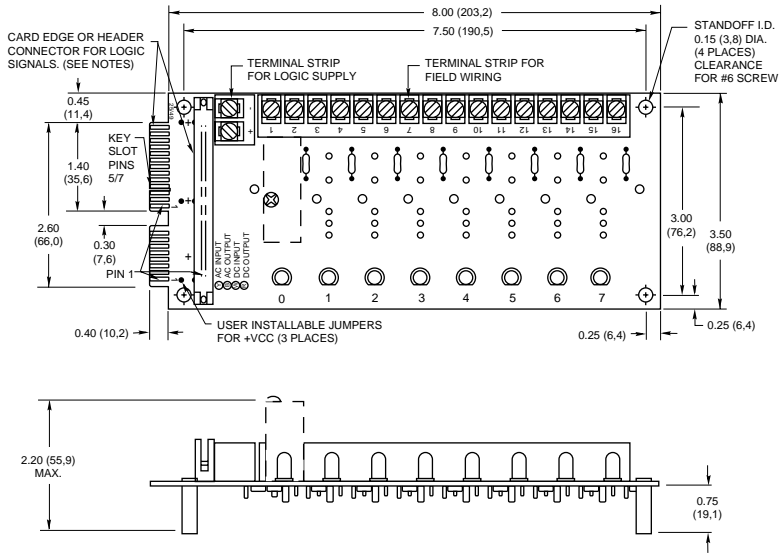

MOUNTING RACKS

SCHEMATIC—Part Nos. 70RCK8, 70MRCK8

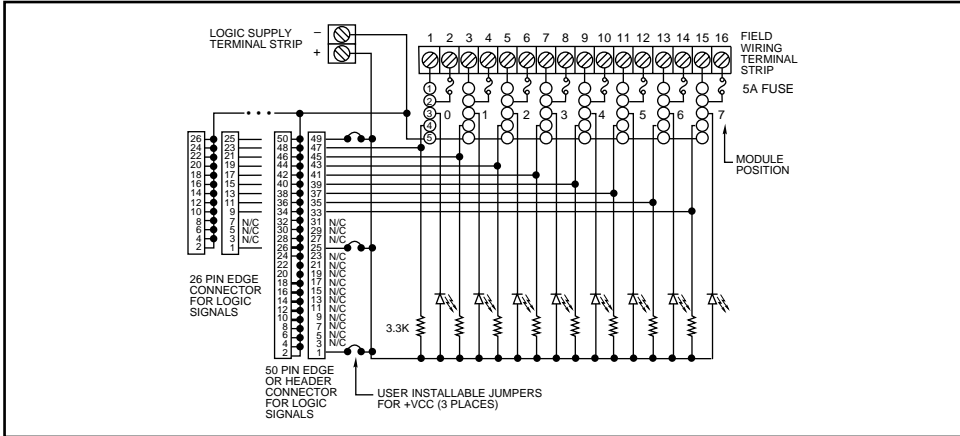

ORDERING INFORMATION (modules ordered separately)

Part Number	I/O	Description	UL	CSA	Style
70RCK8	8	Card edge	X	X	Standard
70RCK8-HL	8	50 Pin header with ejector levers	X	X	Standard
70MRCK8-EC	8	Card edge	X	X	Mini
70MRCK8-HL	8	50 Pin header with ejector levers	X	X	Mini
70GRCK8-HL	8	50 Pin header with ejector levers	X	X	G5

ENGINEERING INFORMATION

See pages 48-49.

Available from your local Grayhill Distributor
For prices and discounts, contact a local Sales Office, an authorized local Distributor, or Grayhill.



16 MODULE RACK—Standard

Part No. 70RCK16

Schematic and Ordering Information on pages 58-59.

Dimensions are shown in inches (and millimeters).

All tolerances are ± 0.010 (0,25) unless otherwise specified.

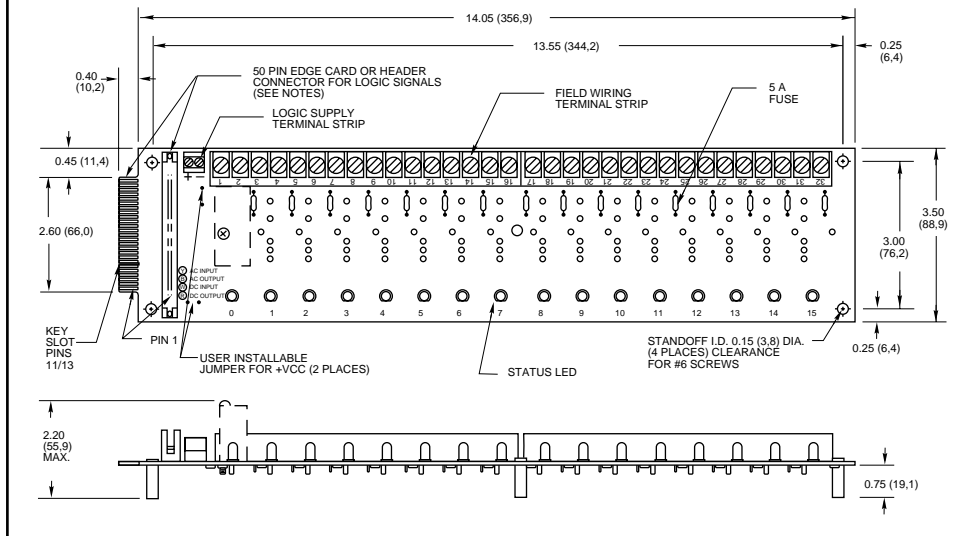

MOUNTING RACKS

SCHEMATIC—Part Nos. 70RCK16 and 70MRCK16

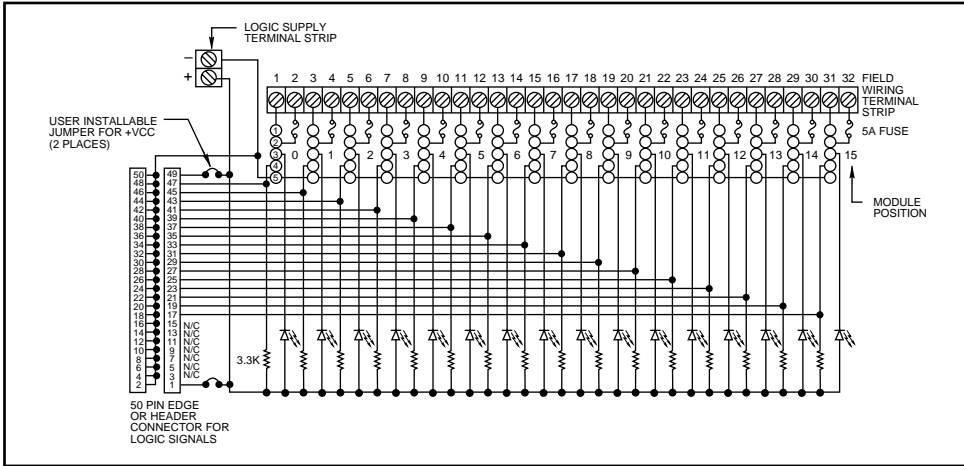

SCHEMATIC—Part No. 70GRCK16

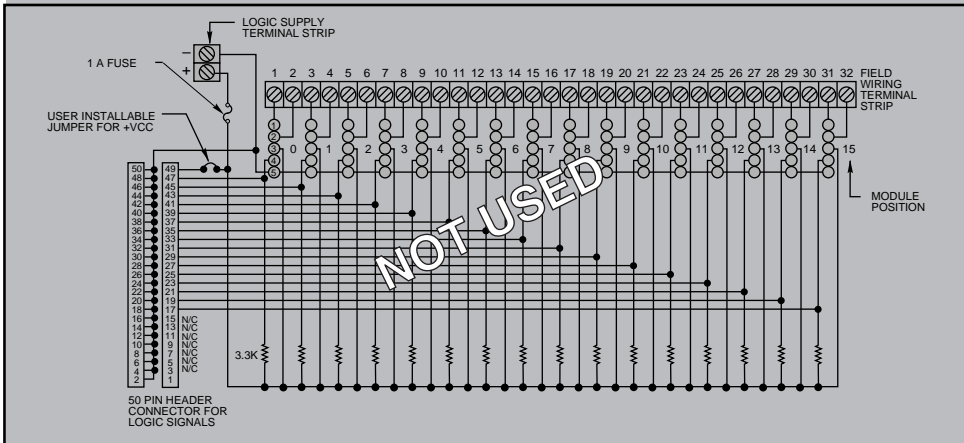

MOUNTING RACKS

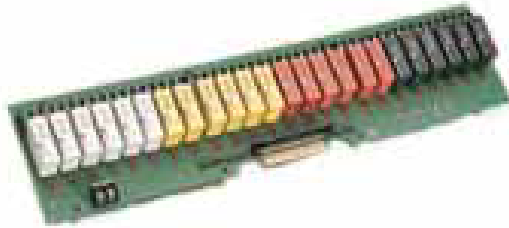

24 MODULE RACK—Standard

Part No. 70RCK24

Dimensions are shown in inches (and millimeters).
Tolerances are ± 0.010 (0,25) unless indicated otherwise.

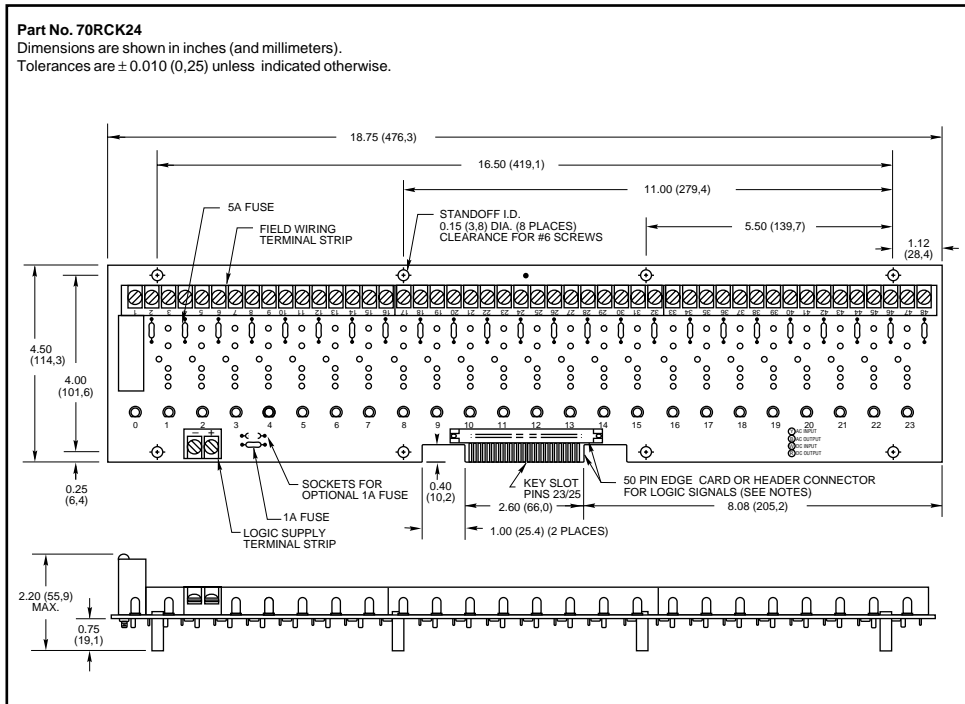

24 MODULE RACK—Miniature

Part No. 70MRCK24

Dimensions are shown in inches (and millimeters).
All tolerances are ± 0.010 (0,25) unless otherwise specified.

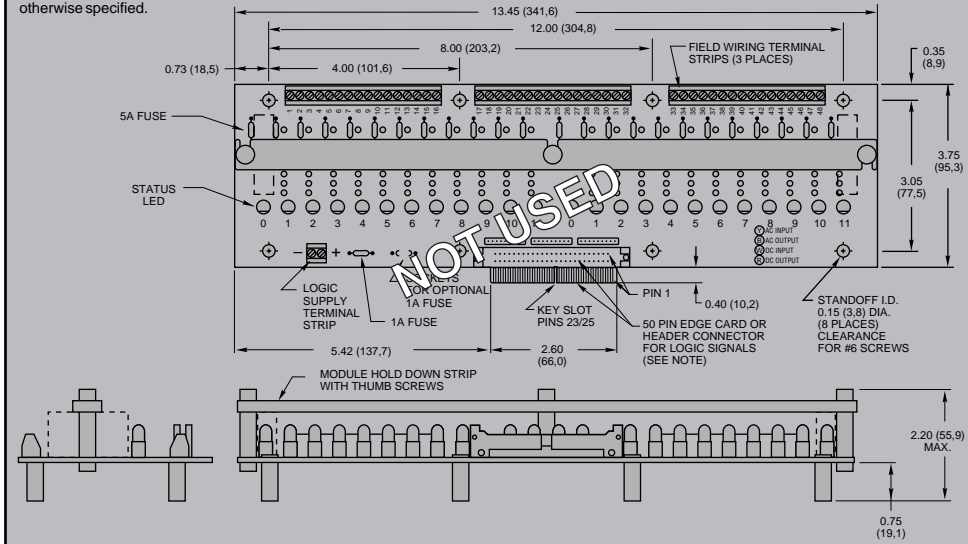

SCHEMATIC—Part Nos. 70RCK24 and 70MRCK24

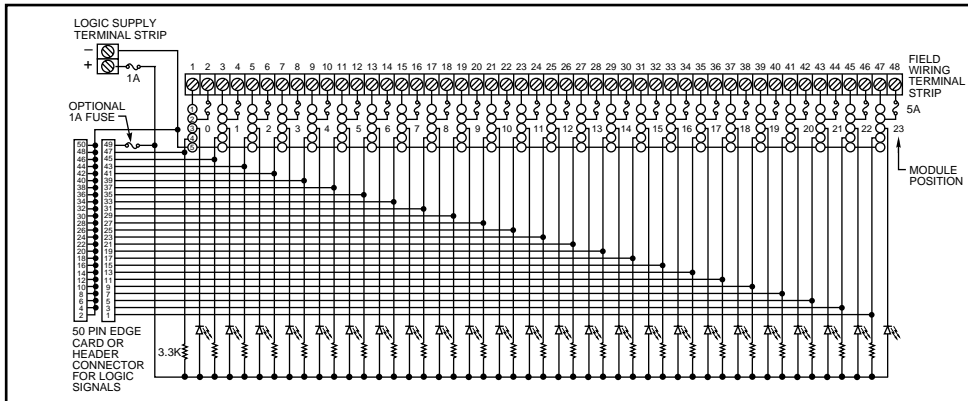

ORDERING INFORMATION (modules ordered separately)

Part Number	I/O	Description	UL	CSA	Style
70RCK24	24	Card edge	X	X	Standard
70RCK24-HL	24	50 Pin header with ejector levers	X	X	Standard
70MRCK24-EC	24	Card edge	X	X	Mini
70MRCK24-HL	24	50 Pin header with ejector levers	X	X	Mini

ENGINEERING INFORMATION

See pages 48-49.

Available from your local Grayhill Distributor
For prices and discounts, contact a local Sales
Office, an authorized local Distributor, or Grayhill.



561 Hillgrove Avenue • LaGrange, Illinois 60525 • USA • Phone: (708) 354-1040 • Fax: (708) 354-2820 • <http://www.grayhill.com>

61

70YY19038 501 ENG3108

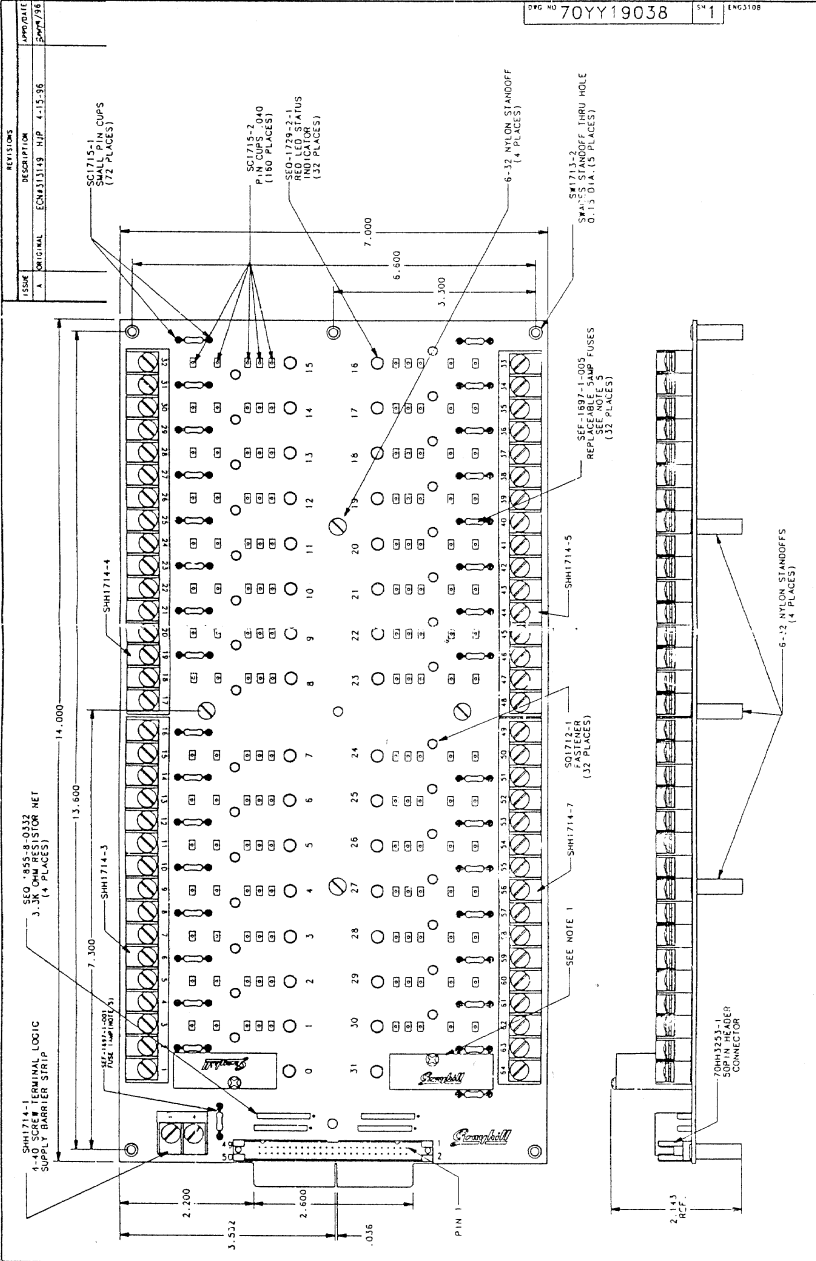

APPROVED DATE	DATE	DESIGNER	DATE	DR
4-17-56	4-17-56	W. J. BROWN	4-17-56	W. J. BROWN
4-28-56	4-28-56	W. J. BROWN	4-28-56	W. J. BROWN
4-15-56	4-15-56	W. J. BROWN	4-15-56	W. J. BROWN

UNLESS OTHERWISE SPECIFIED	ALL DIMENSIONS	IN INCHES
UNLESS OTHERWISE SPECIFIED	ALL DIMENSIONS	IN INCHES
UNLESS OTHERWISE SPECIFIED	ALL DIMENSIONS	IN INCHES
UNLESS OTHERWISE SPECIFIED	ALL DIMENSIONS	IN INCHES
UNLESS OTHERWISE SPECIFIED	ALL DIMENSIONS	IN INCHES

DESIGNED BY	W. J. BROWN
CHECKED BY	W. J. BROWN
DATE	4-15-56
SCALE	FULL
ISSUE	A

NOTES:

1. MODULES NOT SUPPLIED WITH RACK. SHOWN FOR REFERENCE ONLY.
2. POLARITY REVERSAL MAY PERMANENTLY DAMAGE LED STATUS INDICATORS.
3. RACK TO BE PRINTED WITH E.I.A. DATE CODE - YEAR AND WEEK.
4. LONG EJECT LEVERS TO BE PACKAGED AND SHIPPED WITH THE FINAL ASSEMBLY.
5. REPLACEMENT FUSE: 1 AMP LITTLEFUSE P/M 251-001 BUSMAN FUSE P/M 0FAL10005 BUSMAN FUSE P/M 0FAS10005

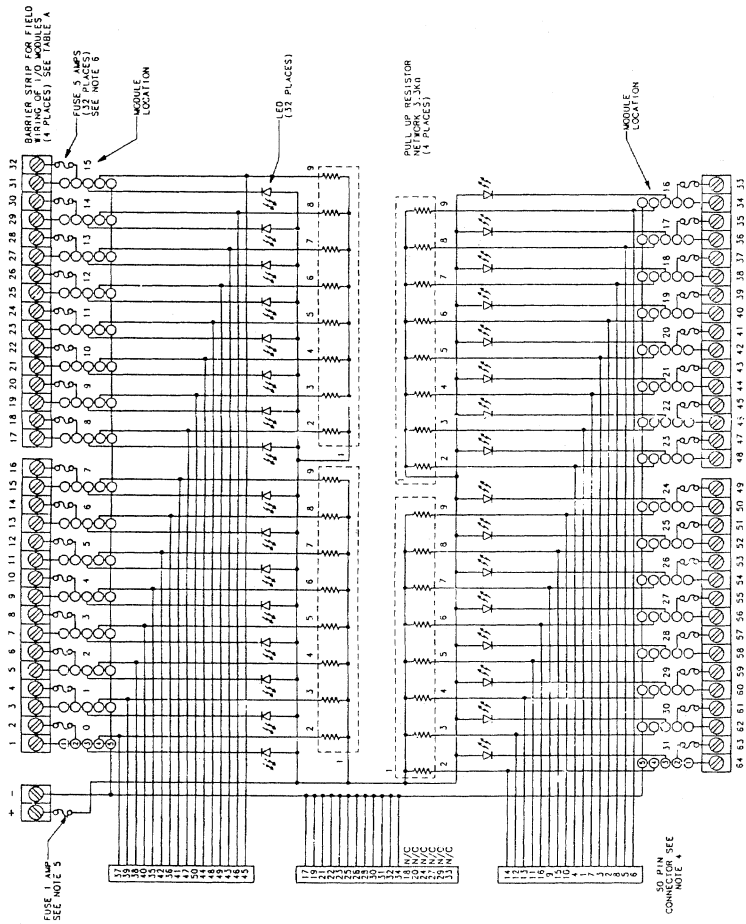

APPROVED DATE 4-19-78	DESIGNED DATE 10-20-77	DATE CHECKED 4-13-78	SCALE FULL
UNLESS OTHERWISE SPECIFIED TOLERANCES ARE: FRACTIONS: ±0.005 DECIMALS: ±0.0025 ANGLES: ±0.005 DIMENSIONS: ±0.005	ALUMINUM DIMENSIONS: ±0.005 STEEL DIMENSIONS: ±0.005 WELDING: ±0.005 HOLE POSITION: ±0.005	FINISH: 1. UNLESS OTHERWISE SPECIFIED 2. ALL SURFACES TO BE FINISHED 3. UNLESS OTHERWISE SPECIFIED	ISSUE A
Granhill GRANHILL, INC. 1000 W. 10TH AVENUE, SUITE 100 DENVER, COLORADO 80202			ASSEMBLY I/O PANEL 32 POSITION 70RCK32-HL (ASM I/O RACK 32)
DRAWING NO. 81073	SIZE C	SHEET NO. 2 OF 2	SHEET NO. 2 OF 2

DIGITAL I/O MODULE MOUNTING BOARDS

FOR 0.6 INCH MODULES (Compatible with "SM" Series Modules)

PB-8H

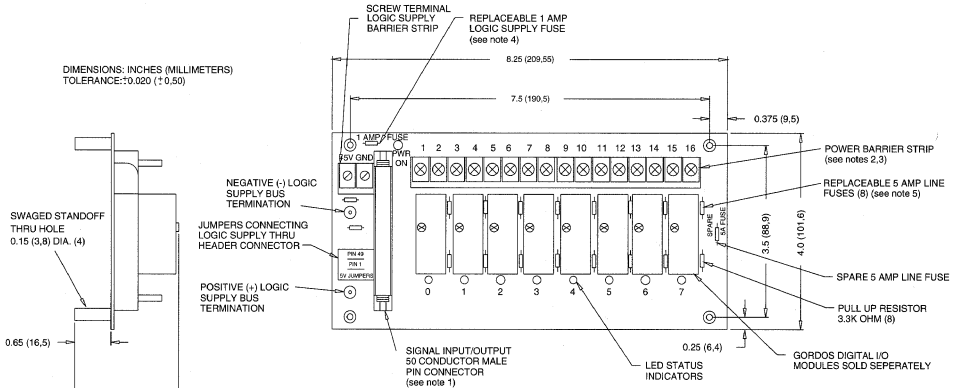

- NOTES: 1) CONNECTOR IS CIRCUIT ASSEMBLY CA-50H-2B-SR OR EQUIVALENT.
2) 6-32 SCREW TERMINAL BARRIER STRIPS ACCEPT WIRE SIZES FROM 24 TO 12 AWG.
3) OPTIONAL JUMPERS ARE AVAILABLE TO INTERCONNECT BARRIER STRIP COMMONS. ORDER 1 EACH "J5-B".
4) LITTLE FUSE 251001 OR EQUIVALENT.
5) LITTLE FUSE 251005 OR EQUIVALENT.

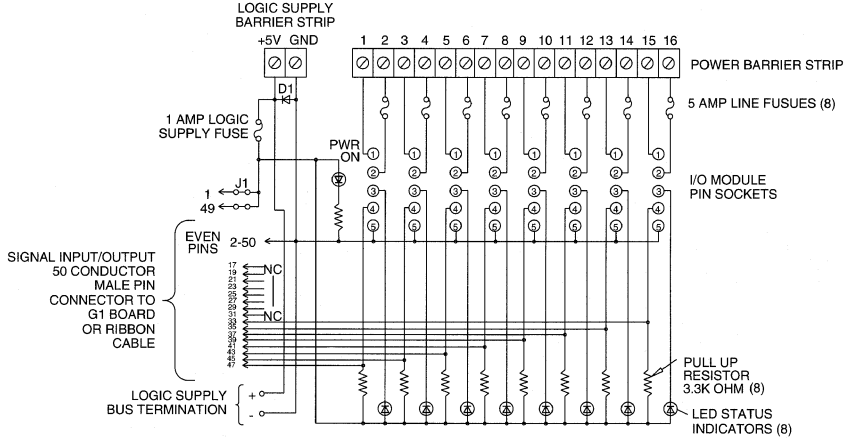

Products and specifications subject to change without notice.
Consult factory for application assistance.

3237 Commander, Carrollton, Texas 75006 / Tel: (972) 250-1647 / (800) 677-5311 / FAX: (972) 250-3865

2-39

DIGITAL I/O MODULE MOUNTING BOARDS

FOR 0.6 INCH MODULES (Compatible with "SM" Series Modules)

PB-16H

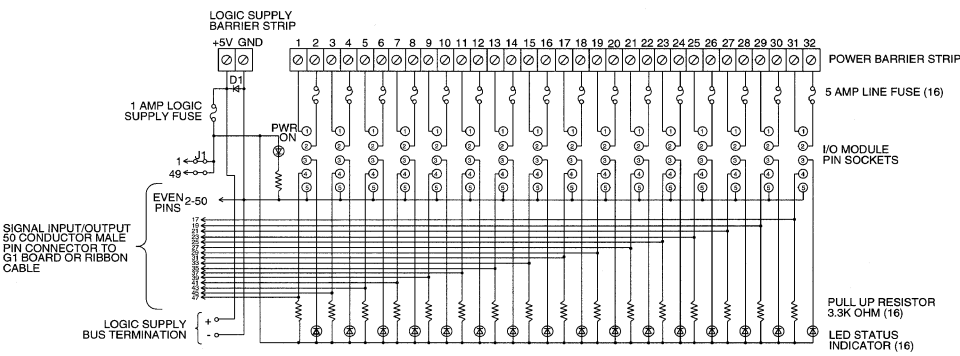
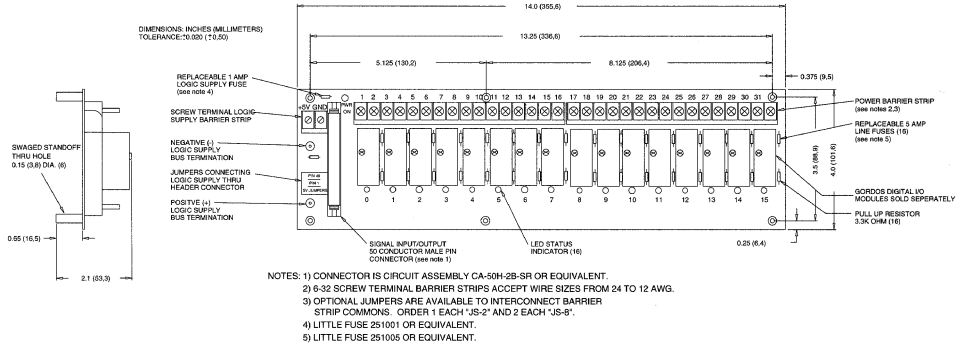

Products and specifications subject to change without notice.
Consult factory for application assistance.

3237 Commander, Carrollton, Texas 75006 / Tel: (972) 250-1647 / (800) 677-5311 / FAX: (972) 250-3865

DIGITAL I/O MODULE MOUNTING BOARDS

FOR 0.6 INCH MODULES (Compatible with "SM" Series Modules)

PB-24

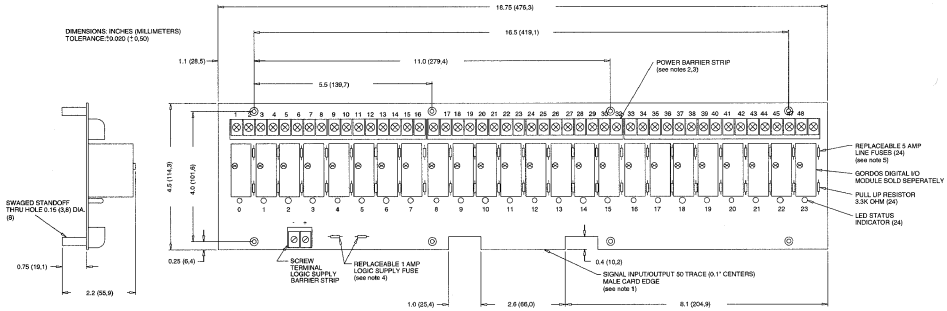

- NOTES: 1) MATING CONNECTOR IS BERG 69317-180 OR EQUIVALENT. SPECIFY SUFFIX 'D' FOR OPTIONAL 69623-093 OR EQUIVALENT MALE PIN CONNECTOR FOR PARALLEL-TO-THE-BOARD CABLE CONNECTION. SPECIFY SUFFIX 'V' FOR OPTIONAL CIRCUIT ASSEMBLY CA-50H-2B-SR OR EQUIVALENT MALE PIN CONNECTOR FOR PERPENDICULAR-TO-THE-BOARD CABLE CONNECTION.
- 2) 6-32 SCREW TERMINAL BARRIER STRIPS ACCEPT WIRE SIZES FROM 24 TO 12 AWG.
- 3) OPTIONAL JUMPERS ARE AVAILABLE TO INTERCONNECT BARRIER STRIP COMMONS. ORDER 2 EACH '-IS-2' AND 3 EACH '-IS-8'.
- 4) LITTLE FUSE 251001 OR EQUIVALENT.
- 5) LITTLE FUSE 251005 OR EQUIVALENT.

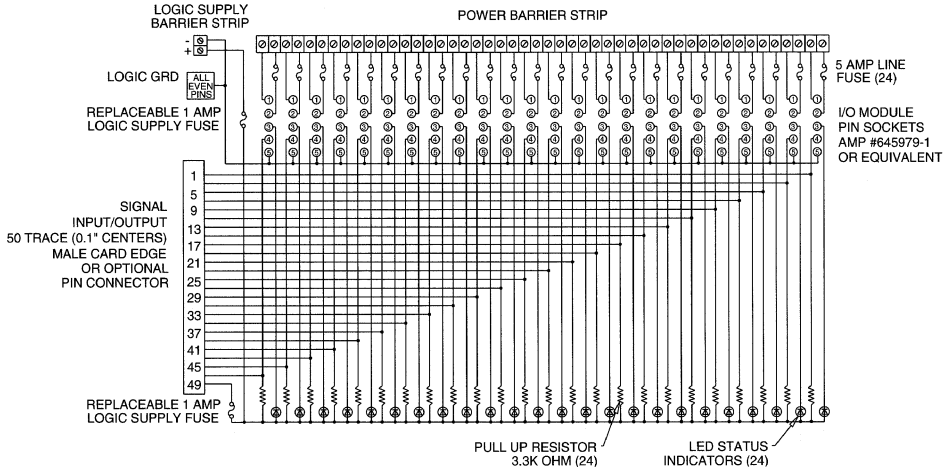

Products and specifications subject to change without notice.
Consult factory for application assistance.

3237 Commander, Carrollton, Texas 75006 / Tel: (972) 250-1647 / (800) 677-5311 / FAX: (972) 250-3865

DIGITAL I/O MODULE MOUNTING BOARDS

FOR 0.6 INCH MODULES (Compatible with "SM" Series Modules)

PB-32D

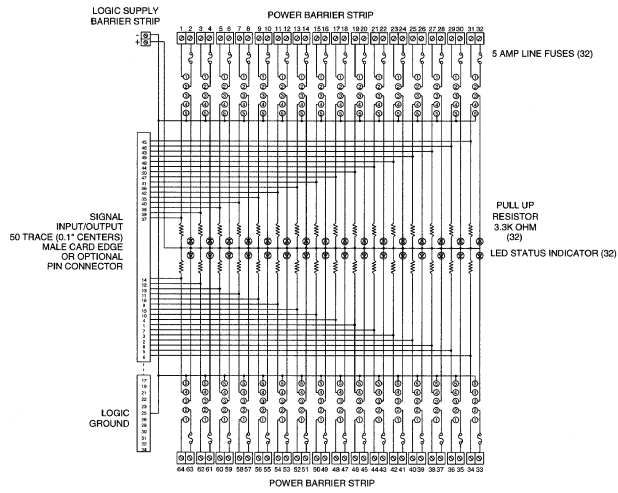
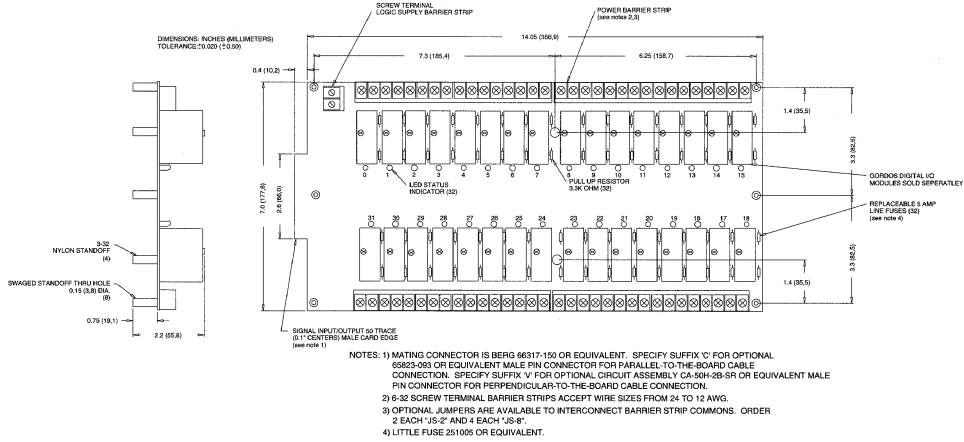

Products and specifications subject to change without notice.
Consult factory for application assistance.

3237 Commander, Carrollton, Texas 75006 / Tel: (972) 250-1647 / (800) 677-5311 / FAX: (972) 250-3865